

CRIPPLE WALL BRACING LAYOUT (PLAN VIEW)

NUMBER OF STORIES ABOVE CRIPPLE WALL	MINIMUM SILL PLATE CONNECTION AND MAXIMUM SPACING
ONE STORY	1/2 INCH DIAMETER ANCHOR SPACED 6 FEET O.C. WITH WASHER PLATE
TWO STORIES	1/2 INCH DIAMETER ANCHOR SPACED 4 FEET O.C. WITH WASHER PLATE; OR 5/8 INCH DIAMETER ANCHOR SPACED 6 FEET O.C. WITH WASHER PLATE
THREE STORIES	5/8 INCH DIAMETER ANCHOR SPACED 4 FEET O.C. WITH WASHER PLATE

NUMBER OF STORIES	SILL PLATE ANCHORAGE FOR VARIOUS LENGTHS OF SILL PLATE		
	LESS THAN 12 FEET TO 6 FEET	LESS THAN 6 FEET TO 30 INCHES	LESS THAN 30 INCHES
ONE STORY	THREE CONNECTIONS	TWO CONNECTIONS	ONE CONNECTION
TWO STORIES	FOUR CONNECTIONS FOR 1/2-INCH ANCHOR OR BOLTS OR THREE CONNECTIONS FOR 5/8-INCH ANCHORS OR BOLTS	TWO CONNECTIONS	ONE CONNECTION
THREE STORIES	FOUR CONNECTIONS	TWO CONNECTIONS	ONE CONNECTION

NOTE: - ANCHOR BOLTS SHALL BE PLACED WITHIN 12 INCHES, BUT NOT LESS THAN 9 INCHES, FROM THE ENDS OF SILL PLATES AND IN THE CENTER OF THE STUD SPACE CLOSEST TO THE REQUIRED SPACING. - SIMPSON STRONG-TIE® UFP10 RETROFIT FIT PLATE MAY BE USED AS A SUBSTITUTE FOR ANCHOR BOLTS ON A 1 TO 1 BASIS.

MINIMUM ANCHOR DIAMETER AND SPACING

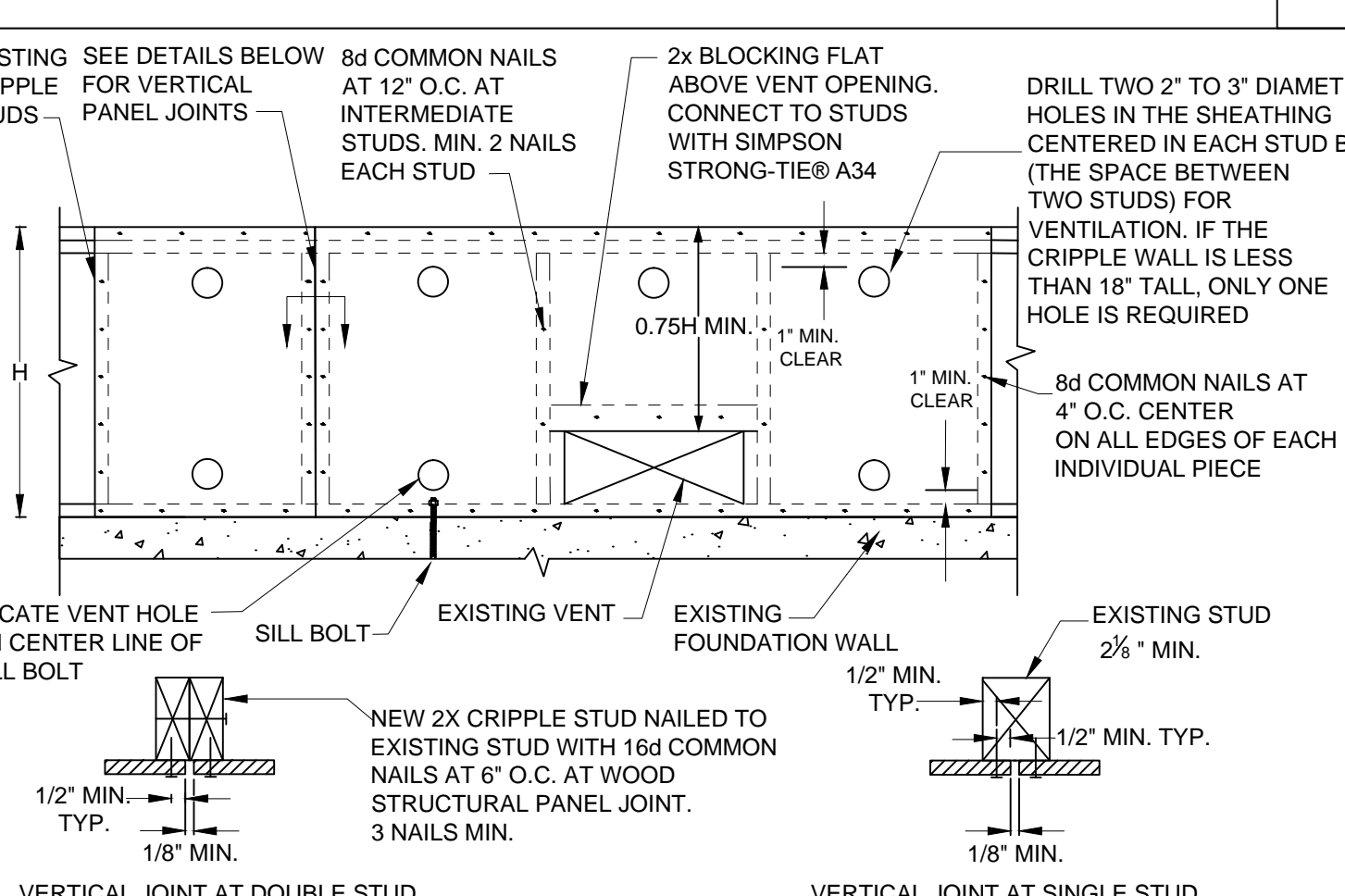

PARTIAL CRIPPLE STUD WALL ELEVATION

POST INSTALLED ANCHOR SOLUTIONS

MUDSILL THICKNESS (IN)	HOLE DEPTH IN FOUNDATION (IN)	SIMPSON STRONG-TIE® TITEN HD® DIA. X LENGTH (IN)	SIMPSON STRONG-TIE® SET-XP® ADHESIVE	SIMPSON STRONG-TIE® BEARING PLATE
1 1/2	5	1/2" x 6"	RFB#4X8	BP 1/2"
		5/8" x 6"	RFB#5X8	BP 5/8"
2	4 1/2	1/2" x 6"	RFB#4X8	BP 1/2"
		5/8" x 6"	RFB#5X8	BP 5/8"
2 1/2	4 1/2	1/2" x 6 1/2"	RFB#4X10	BP 1/2"
		5/8" x 6 1/2"	RFB#5X10	BP 5/8"
3	5 1/2"	1/2" x 8"	RFB#4X10	BP 1/2"
		5/8" x 8"	RFB#5X10	BP 5/8"

NOTE: - SEE DETAIL 2 FOR MINIMUM ANCHOR DIAMETER AND SPACING. NOTCH BLOCKING AT ANCHOR BOLT. - USE BP - 3 WHERE 3"X3" PLATE WASHERS ARE REQUIRED. - RFB ANCHORS AND BP PLATES ARE AVAILABLE IN HOT-DIPPED GALVANIZED (HDG) COATING. - TITEN HD ANCHORS ARE AVAILABLE IN MECHANICALLY GALVANIZED (MG) COATING. - SEE GENERAL NOTES FOR PROPER DRILL BIT SIZE FOR ANCHORS. - BEARING PLATES WITH SLOTTED HOLES (BPs.) PROVIDE ADJUSTABILITY. INSTALL STANDARD CUT WASHER BETWEEN NUT AND SLOTTED HOLE BEARING PLATES

ANCHOR AND WASHER PLATE SELECTION FOR DIFFERENT SILL THICKNESS

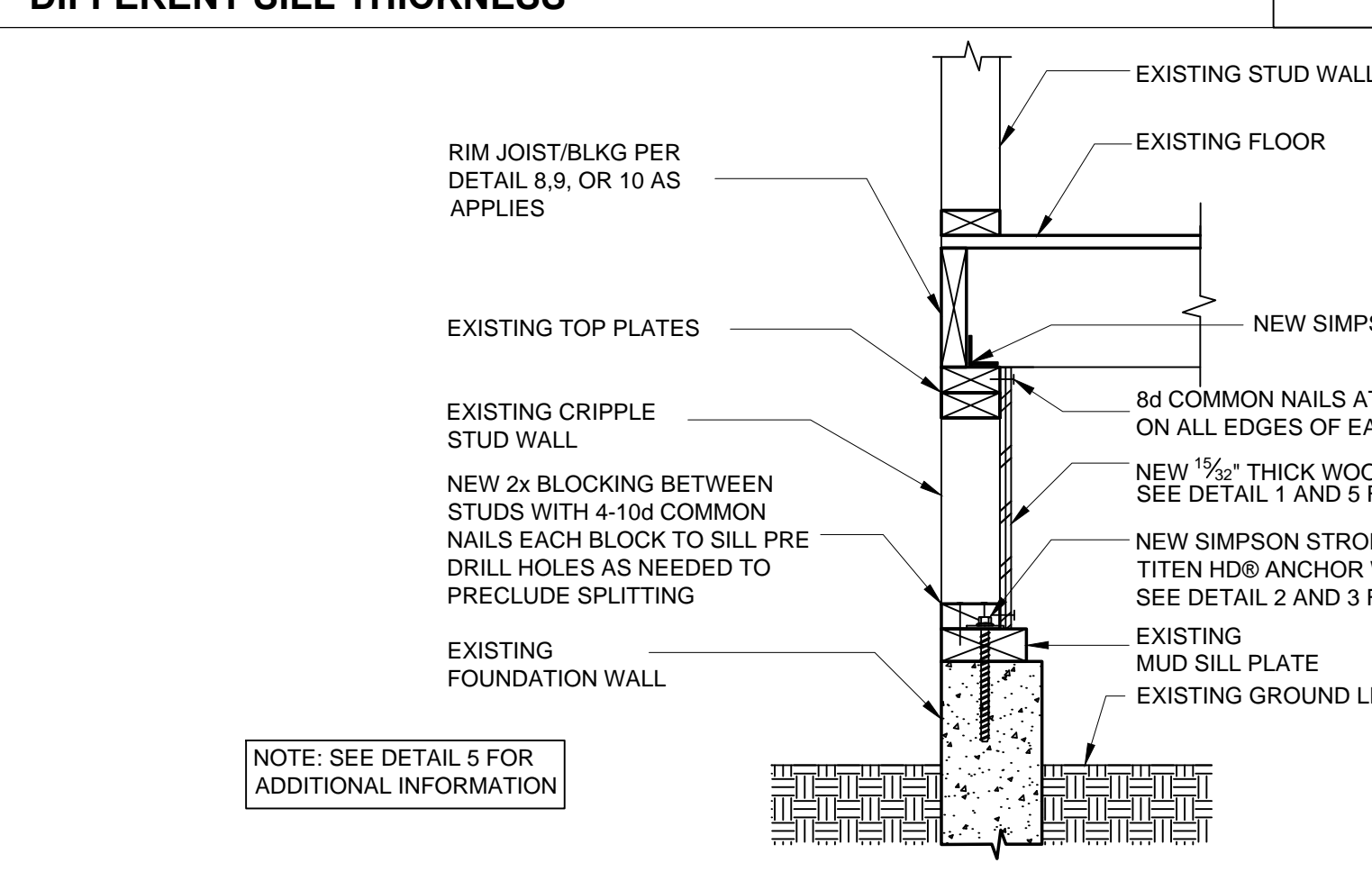

CRIPPLE WALL BRACING ON INTERIOR FACE OF CRIPPLE STUDS

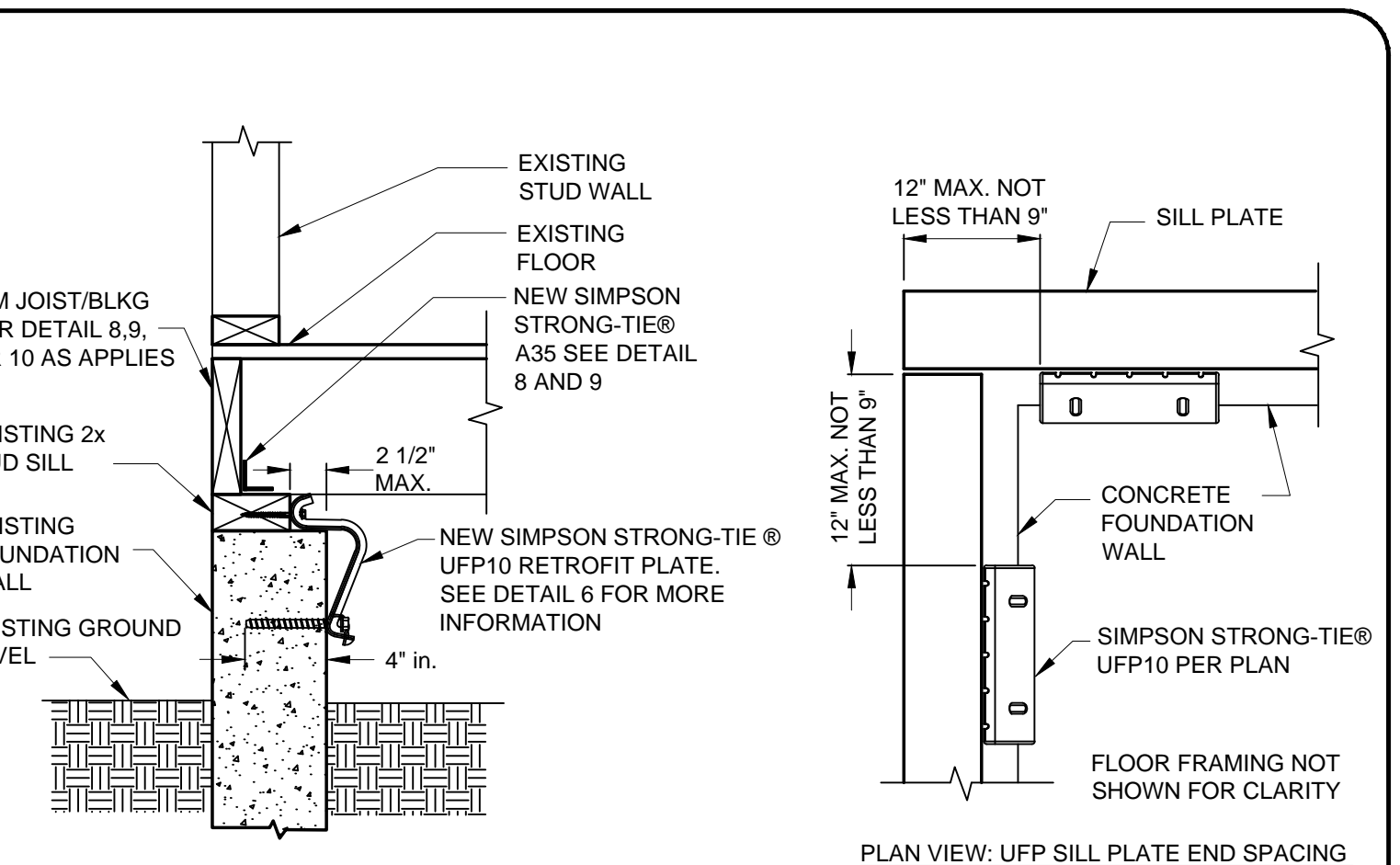

ALTERNATE SILL PLATE BOLTING TO EXISTING FOUNDATION WITHOUT CRIPPLE WALL

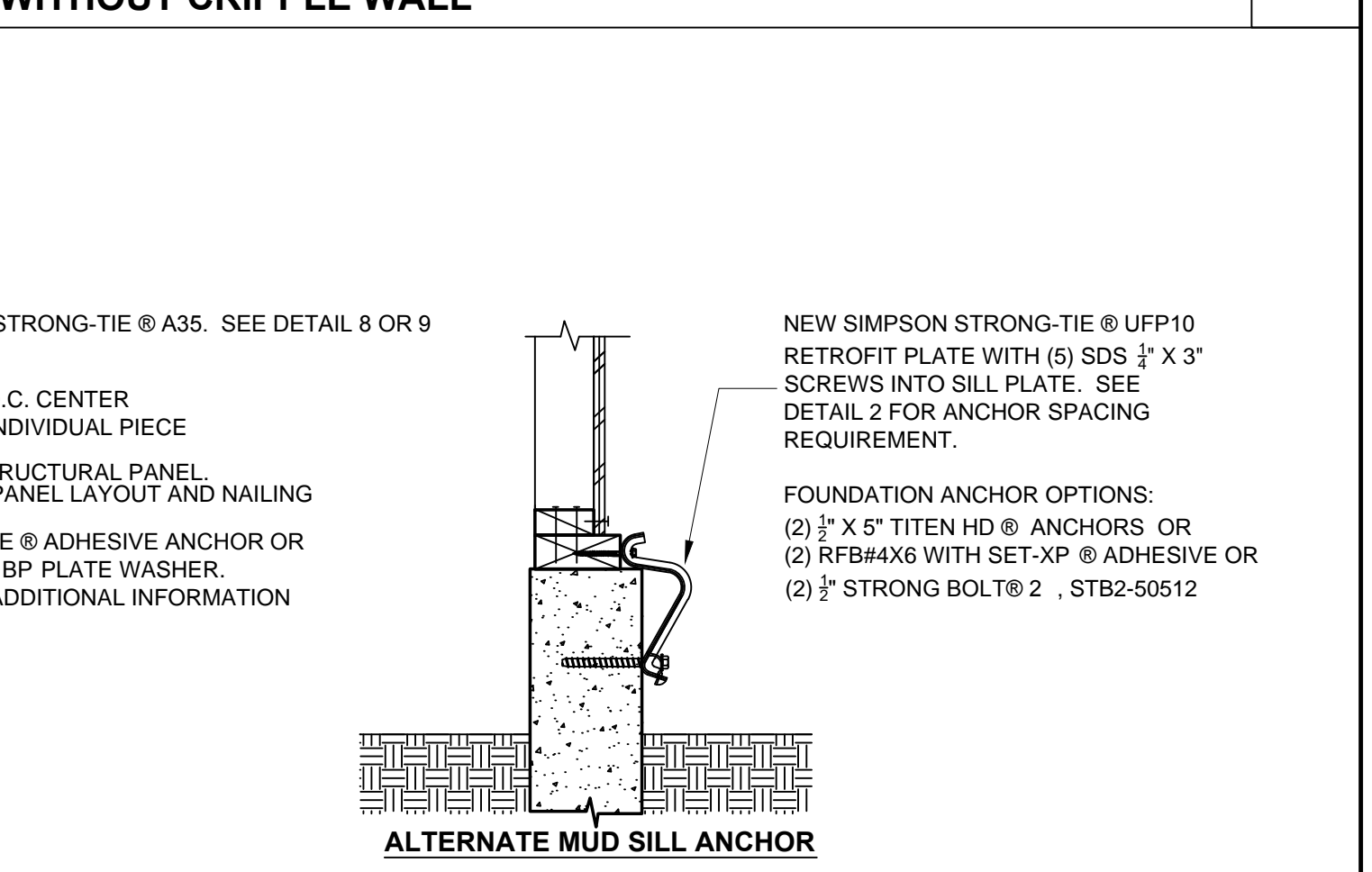

CRIPPLE WALL BRACING ON EXTERIOR FACE OF CRIPPLE STUDS

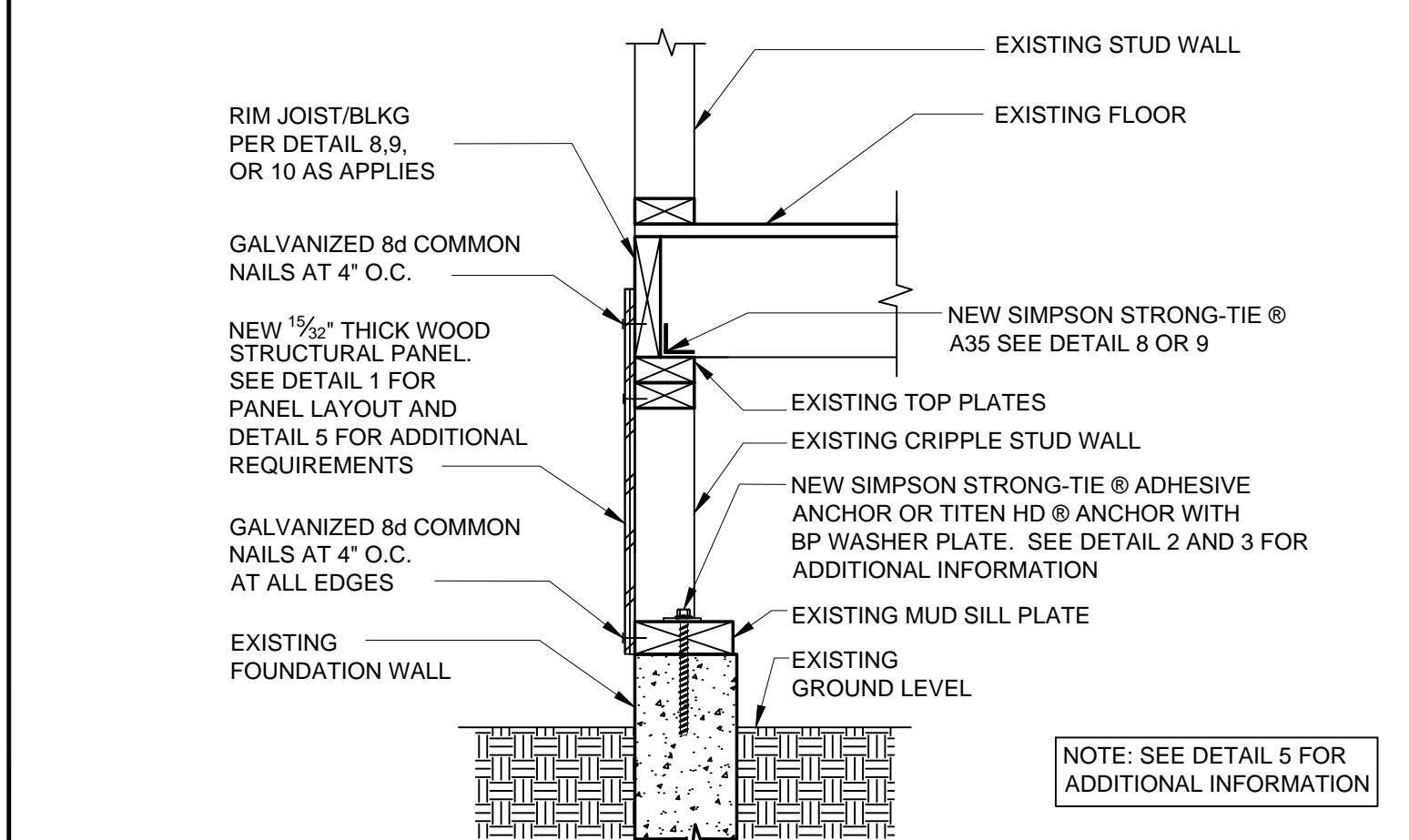

CRIPPLE WALL BRACING ON EXTERIOR FACE OF CRIPPLE STUDS

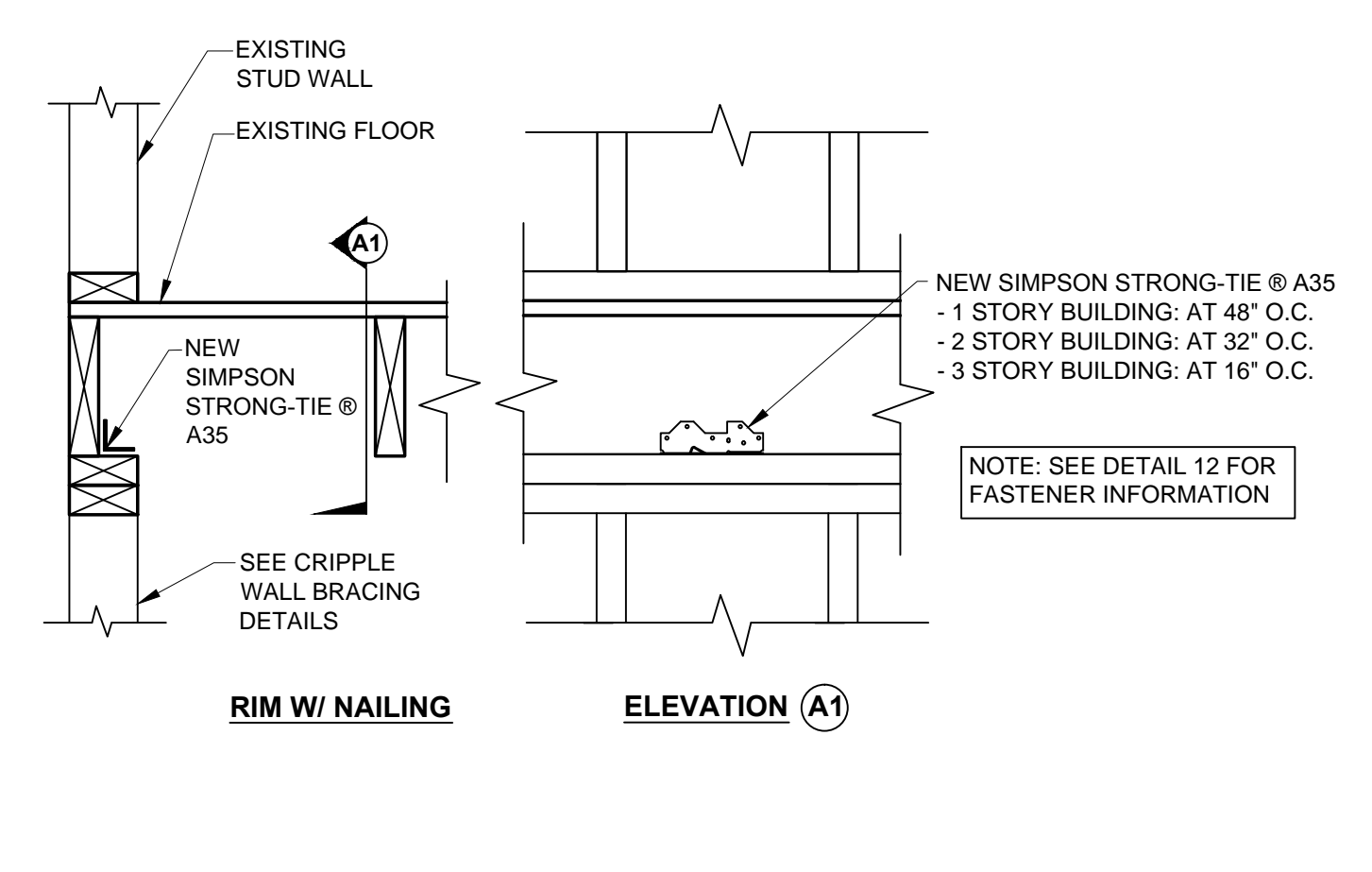

FLOOR JOISTS PARALLEL TO FOUNDATION

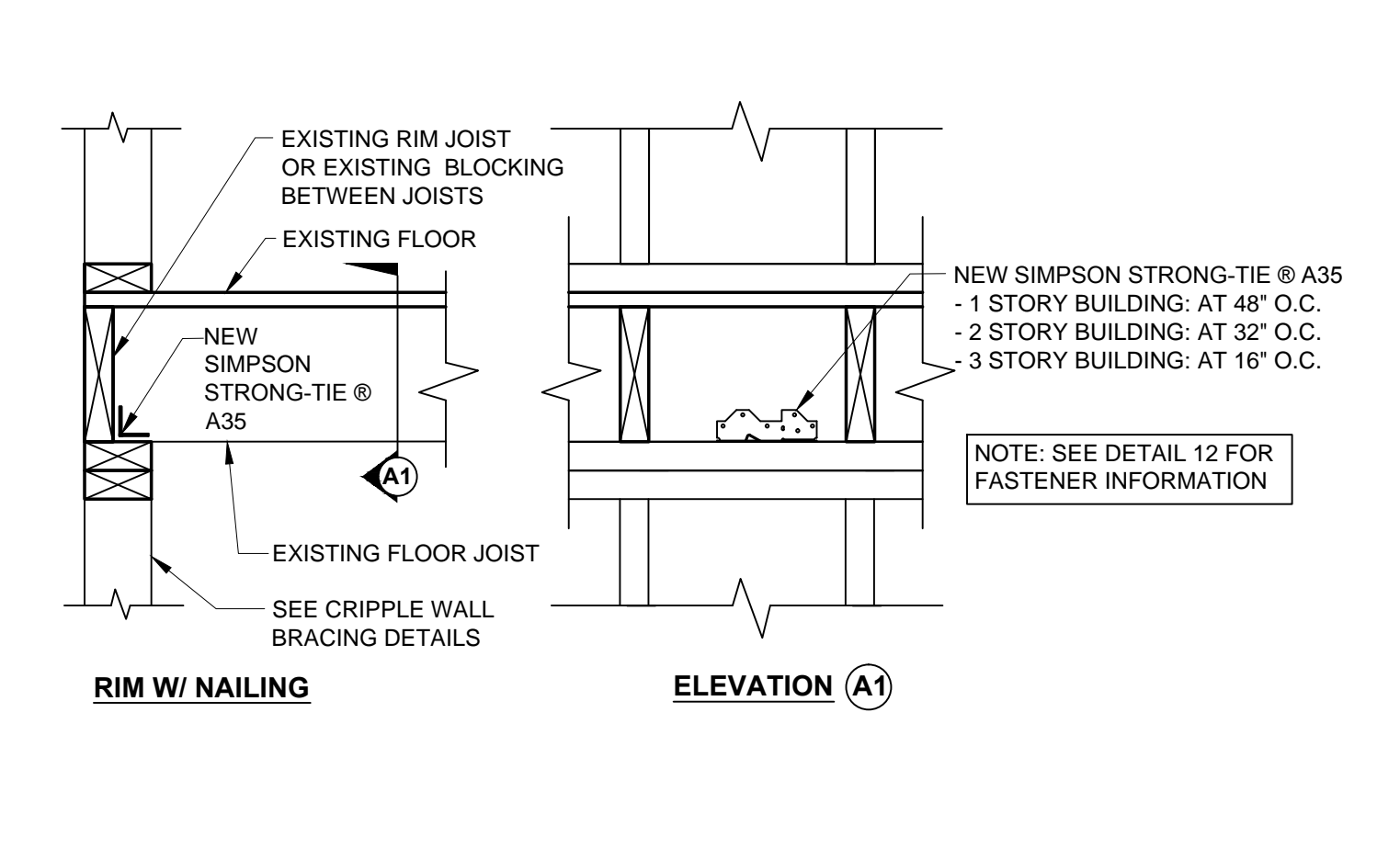

FLOOR JOISTS PERPENDICULAR TO FOUNDATION WITH EXISTING RIM JOIST OR BLOCKING

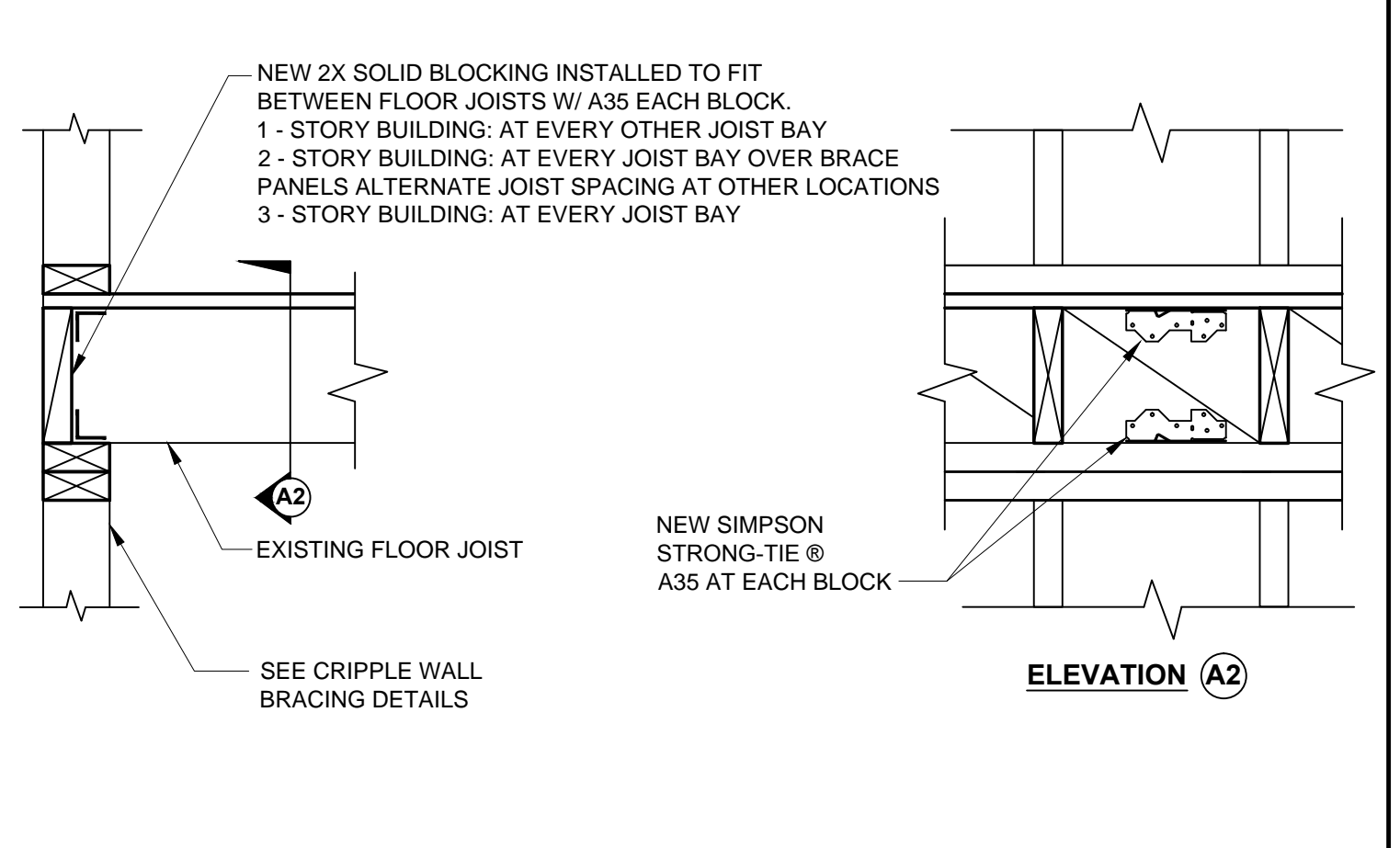

FLOOR JOIST PERPENDICULAR TO FOUNDATION WITH NO EXISTING RIM JOIST OR BLOCKING

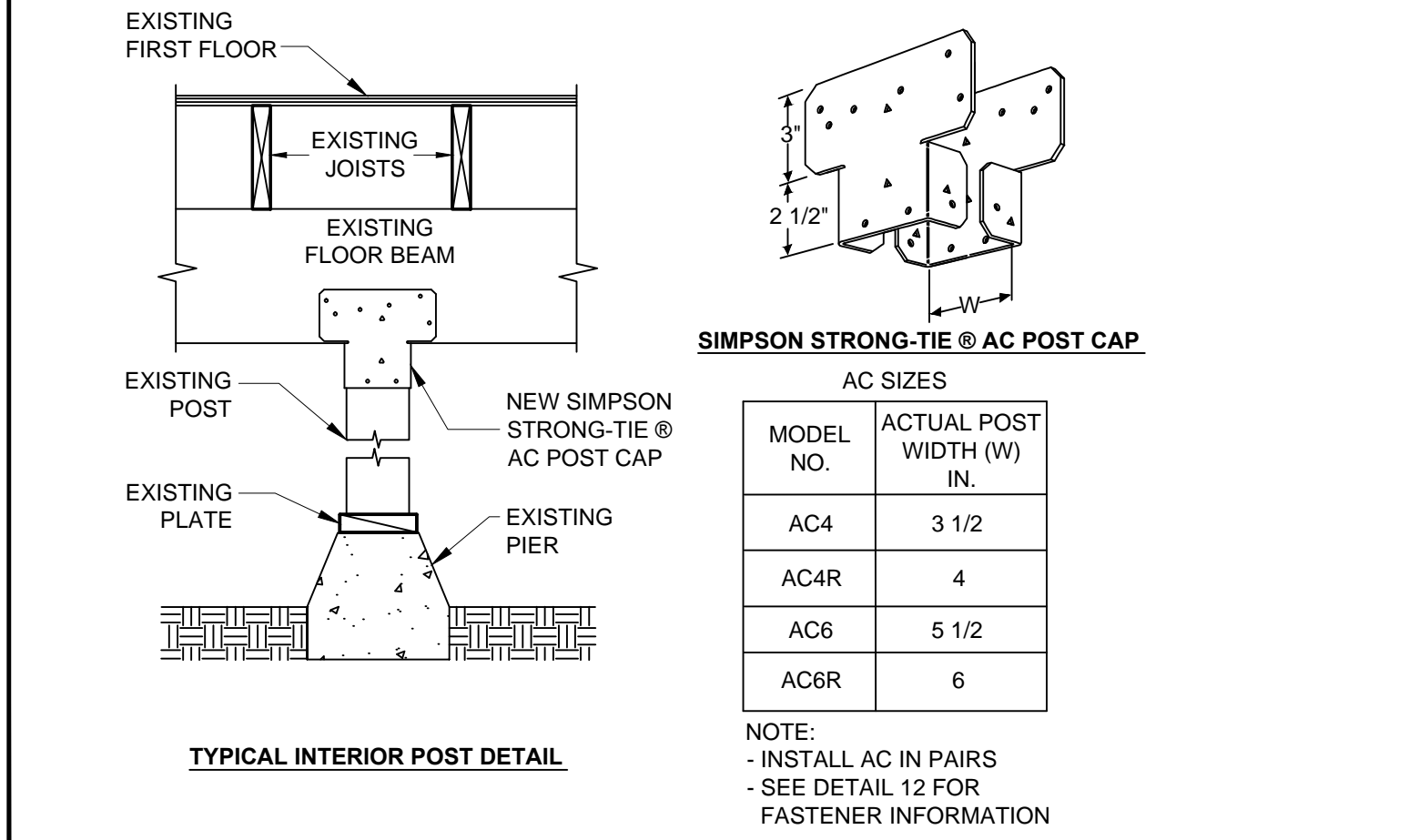

FLOOR BEAM TO POST (OPTIONAL)

SIMPSON STRONG-TIE® STRONG-DRIVE® SD SCREWS

CONNECTOR MODEL NO.	NAILS	SCREW OPTIONS MODEL NO.	
		SIMPSON STRONG-TIE® SD#9 X 1 1/2"	SIMPSON STRONG-TIE® SD#10 X 1 1/2"
A35	8d X 1 1/2"	•	•
LTP4	8d X 1 1/2"	•	•
AC	16d COMMON	•	•

NOTE: • DESIGNED TO REPLACE NAILS IN CERTAIN PRODUCTS, THE SD9 AND SD10 HAVE BEEN DESIGNED AND TESTED FOR USE IN THE MOST POPULAR SIMPSON STRONG-TIE PRODUCTS. • CONTACT SIMPSON STRONG-TIE FOR ADDITIONAL PRODUCTS APPROVED FOR USE WITH STRONG-DRIVE® SD SCREWS.

ALTERNATE SCREW FASTENER TO REPLACE NAILS

THESE SEISMIC RETROFIT DETAILS ARE DESIGNED TO PROMOTE PUBLIC SAFETY AND WELFARE BY REDUCING THE RISK OF EARTHQUAKE INDUCED DAMAGE TO EXISTING HOMES. THESE DETAILS INCLUDE SOME OF THE PRESCRIPTIVE MINIMUM STANDARDS BASED ON THE 2012 INTERNATIONAL EXISTING BUILDING CODE AND ARE INTENDED TO IMPROVE THE SEISMIC PERFORMANCE OF HOMES, BUT WILL NOT NECESSARILY PREVENT EARTHQUAKE DAMAGE.

THESE DETAILS ONLY APPLY TO HOMES WITH CRAWL SPACES AND CRIPPLE WALLS. THEY ADDRESS REINFORCING THE CRIPPLE WALL, BUT NOT THE STORIES ABOVE. DRAWINGS REQUIRE BUILDING DEPARTMENT APPROVAL WHICH MAY INCLUDE STRICTER REQUIREMENTS. CHAPTER A3 OF THE IBC SHALL BE CHECKED FOR ADDITIONAL REQUIREMENTS WHICH MAY INCLUDE STRICTER STANDARDS THAN THOSE PRESCRIBED HERE.

ALL WORK SHALL BE SUBJECT TO INSPECTION BY THE BUILDING OFFICIAL INCLUDING, BUT NOT LIMITED TO, INSTALLATION AND NAILING OF NEW CRIPPLE WALL BRACING. ANY SPECIAL INSPECTION WHEN REQUIRED BY THE BUILDING OFFICIAL IN ACCORDANCE WITH THE BUILDING CODE.

THE SCOPE OF THESE DETAILS ONLY ADDRESS THE FOLLOWING:

- EXISTING FLOOR JOIST FRAMING PARALLEL TO CRIPPLE WALL.
- EXISTING FLOOR JOIST FRAMING PERPENDICULAR TO CRIPPLE WALL.
- ANCHORAGE OF EXISTING FOUNDATION SILL PLATE.
- BRACING OF EXISTING CRIPPLE WALL.

ALL WOOD HARDWARE AND FASTENERS SHALL BE ATTACHED TO EXISTING WOOD FRAMING MEMBERS FREE OF DAMAGE FROM, BUT NOT LIMITED TO, SIGNIFICANT SPLITS, MOLD, DRY ROT OR TERMITE DAMAGE. THE EVALUATION OF EXISTING WOOD FRAMING MEMBERS FOR SIGNIFICANT SPLITS, MOLD, DRY ROT OR TERMITE DAMAGE IS BEYOND THE SCOPE OF THESE DETAILS.

EXISTING UNDER FLOOR VENTILATION SHALL NOT BE REDUCED WITHOUT PROVIDING EQUIVALENT NEW VENTILATION AS CLOSE TO THE EXISTING VENTILATION AS POSSIBLE. THE LENGTH OF THE PANEL SHALL BE INCREASED A DISTANCE EQUAL TO THE LENGTH OF THE OPENING OR ONE STUD SPACE MINIMUM.

GENERAL NOTES

THE DETAILS SHOWN DO NOT APPLY TO THE BUILDINGS, OR ELEMENTS THEREOF, LISTED BELOW. THESE BUILDINGS OR ELEMENTS REQUIRE ANALYSIS BY AN ENGINEER OR ARCHITECT IN ACCORDANCE WITH APPLICABLE CODE(S) TO DETERMINE APPROPRIATE STRENGTHENING.

- GROUP R1, R2 OR R4 OCCUPANCIES WITH MORE THAN FOUR DWELLING UNITS.
- BUILDINGS WITH A LATERAL-FORCE RESISTING SYSTEM USING POLES OR COLUMNS EMBEDDED IN THE GROUND.
- CRIPPLE WALLS THAT EXCEED 4 FEET IN HEIGHT.
- BUILDINGS EXCEEDING THREE STORIES IN HEIGHT AND ANY THREE-STORY BUILDING WITH CRIPPLE WALL STUDS EXCEEDING 14 INCHES IN HEIGHT.
- BUILDINGS WHERE THE BUILDING OFFICIAL DETERMINES THAT CONDITIONS EXIST THAT ARE BEYOND THE SCOPE OF THESE PRESCRIPTIVE REQUIREMENTS.
- BUILDINGS OR PORTIONS THEREOF CONSTRUCTED ON A CONCRETE SLAB ON GRADE.
- SILL PLATES OR FLOOR FRAMING THAT ARE SUPPORTED DIRECTLY ON THE GROUND WITHOUT AN APPROVED FOUNDATION SYSTEM.
- A PERIMETER FOUNDATION SYSTEM THAT IS CONSTRUCTED ONLY OF WOOD POST SUPPORTED ON ISOLATED PAD FOOTINGS.
- PERIMETER FOUNDATION SYSTEMS THAT ARE NOT CONTINUOUS.
- PERIMETER FOUNDATION SYSTEMS THAT IS CONSTRUCTED OF UNREINFORCED MASONRY OR STONE.

INSTALL FOUNDATION ANCHORS USING PROPER SIZE DRILL BIT FOR THE ANCHOR USED. REFER TO THE CURRENT ANCHORING AND FASTENING SYSTEMS CATALOG FOR ADDITIONAL INSTALLATION INFORMATION.

BIT SIZE	EPOXY ANCHORS		MECHANICAL ANCHORS			
	RFB#4	RFB#5	1/2" TITEN HD	5/8" TITEN HD	1/2" STRONG-BOLT	5/8" STRONG-BOLT
	5/8"	3/4"	1/2"	5/8"	1/2"	5/8"

METAL CONNECTORS, ANCHORS, AND FASTENERS WILL CORRODE AND MAY LOSE LOAD-CARRYING CAPACITY WHEN INSTALLED IN CORROSIVE ENVIRONMENTS OR EXPOSED TO CORROSIVE MATERIALS. REFER TO THE CURRENT WOOD CONNECTOR CATALOG FOR ADDITIONAL CORROSION INFORMATION.

ALTERNATE SCREW FASTENER TO REPLACE NAILS

NO.	DATE	REVISIONS

SIMPSON Strong-Tie

HOME OFFICE:
5955 W. LAS POSITAS BLVD.
PLEASANTON, CA 94588
Tel: (800) 999-5099 Fax: (925) 875-0826

SEE US ONLINE
www.simpsonstrong-tie.com

SEISMIC RETROFIT FOR RESIDENTIAL WOOD FRAME CRIPPLE WALLS AND SILL PLATE ANCHORAGE

NAME
DATE 05-30-12
SCALE NO SCALE
CHECKED
RF1
1 OF 1 SHEET
JOB NO.