

Typical Cripplewall

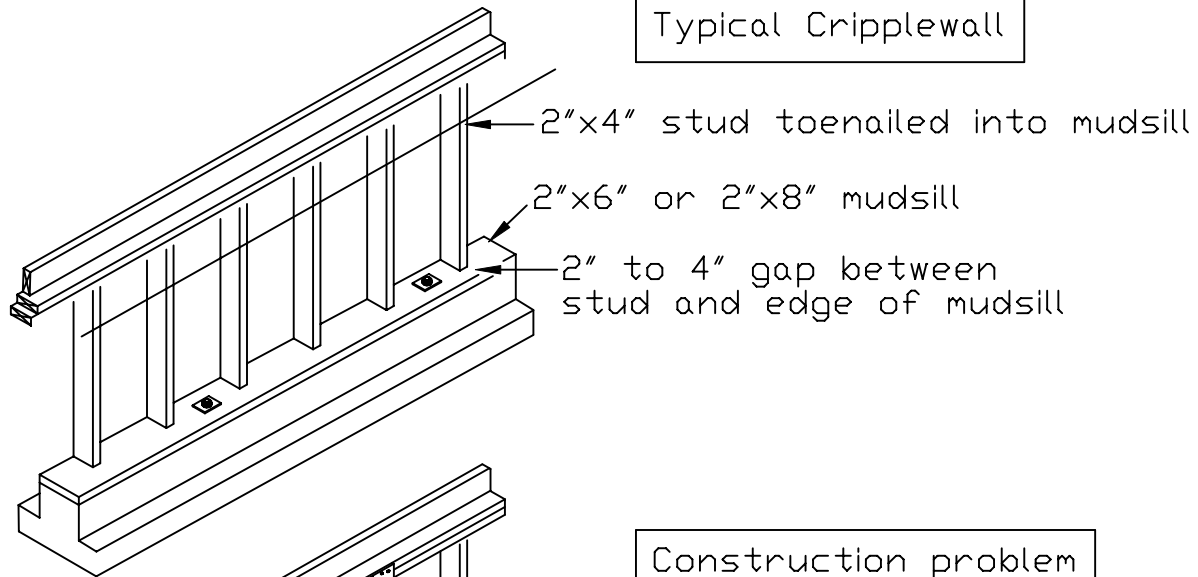

Construction problem

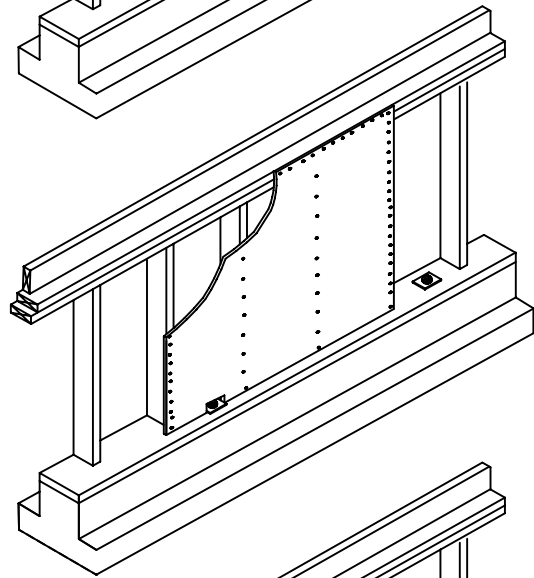

Plywood can be nailed to studs and topplate but cannot be nailed or stapled to mudsill.

Flush Cut solution

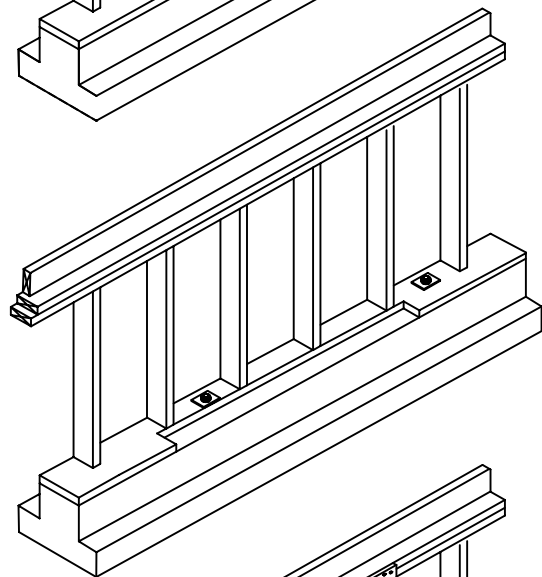

At shear wall locations, mudsill is cut flush with the studs.

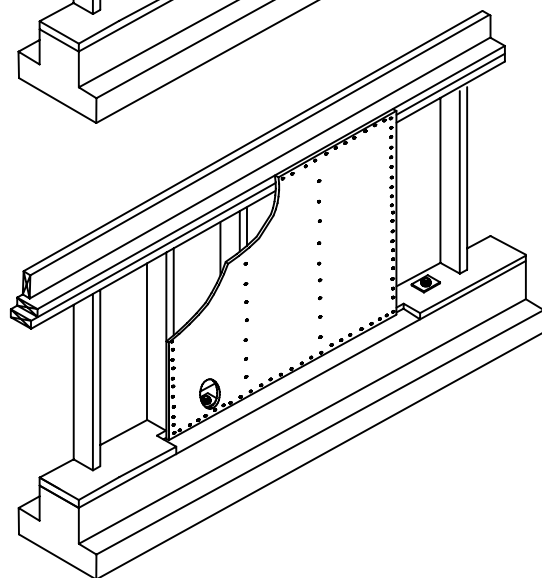

Plywood is then nailed or stapled into studs and flush cut mudsill.

Sill Connection - Four panel flush cut