

Typical Cripplewall

2"x4" stud toenailed into mudsill
 2"x6" or 2"x8" mudsill
 to use reverse block method a 2-4" gap must exist between stud and edge of mudsill

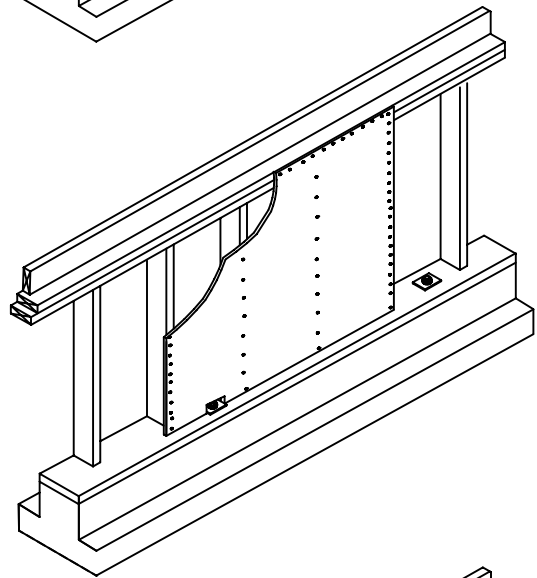

Construction problem

Plywood can be nailed to studs and topplate but cannot be nailed or stapled to mudsill.

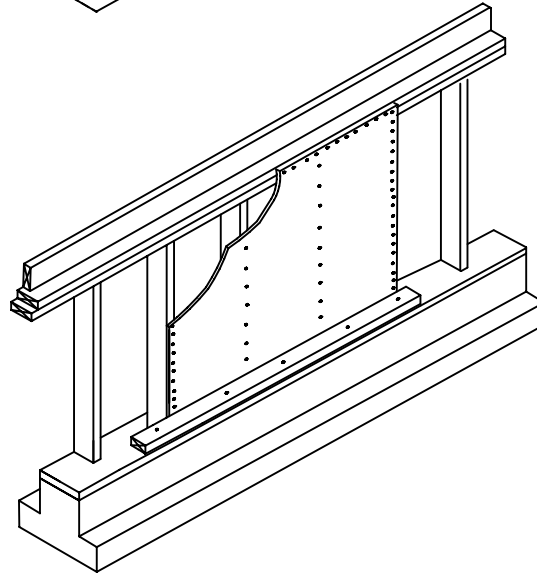

Reverse-block solution

Plywood is edge nailed to new 2 x 4 block with 8d commons 2" o.c. staggered.

Block is then face nailed into mudsill with 12d commons 3" o.c. staggered.

Plywood is edge nailed 2" o.c. and field-nailed 12" o.c. with 8d commons.

This can only be done when distance from face of mudsill to stud is 2" or greater