

PLAN VIEW

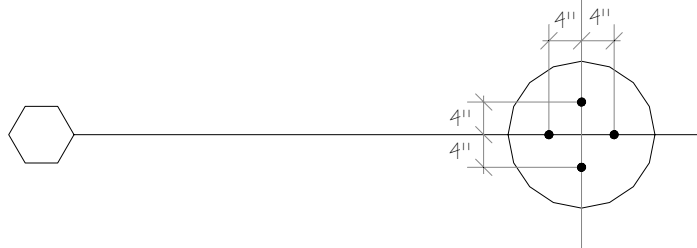

ANCHOR BOLT LAYOUT

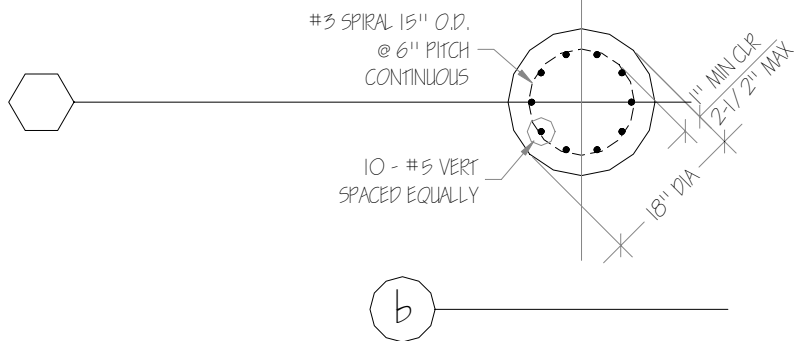

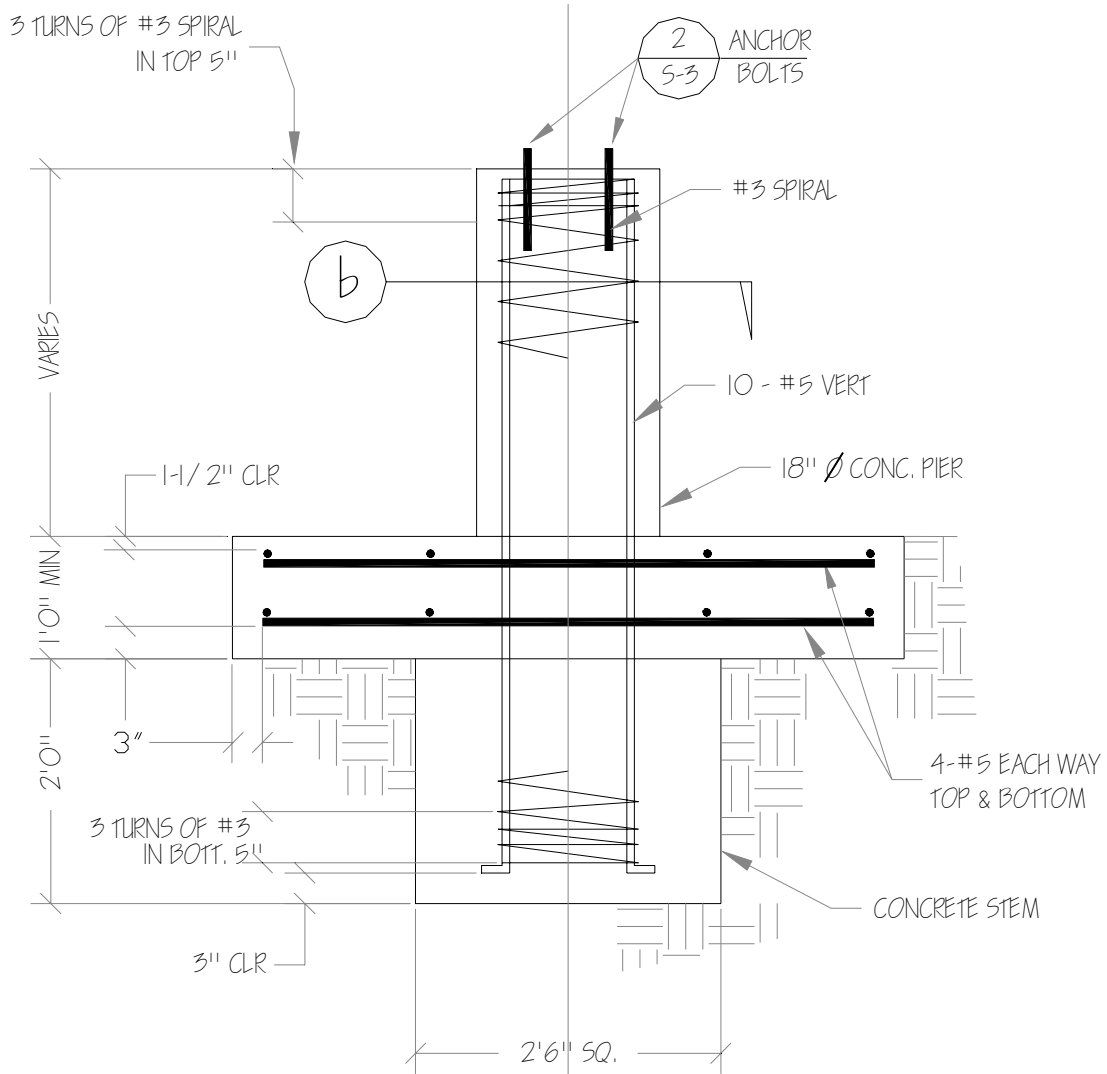

a NO SCALE

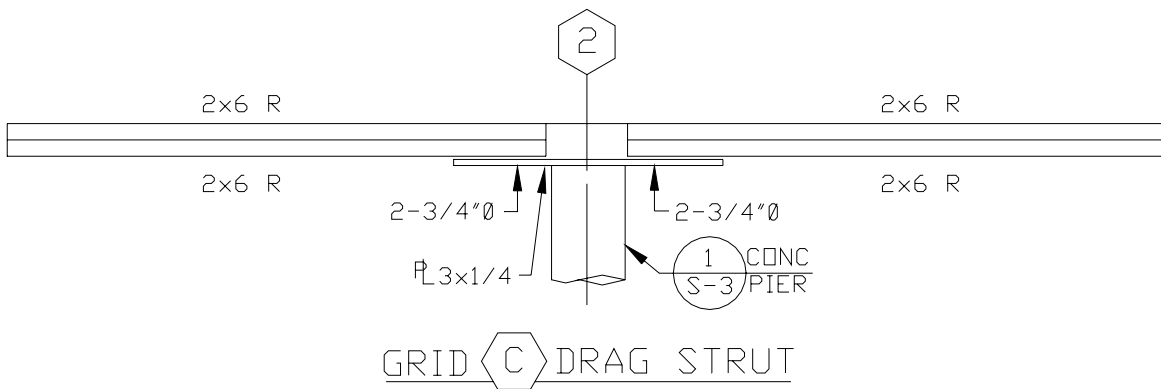
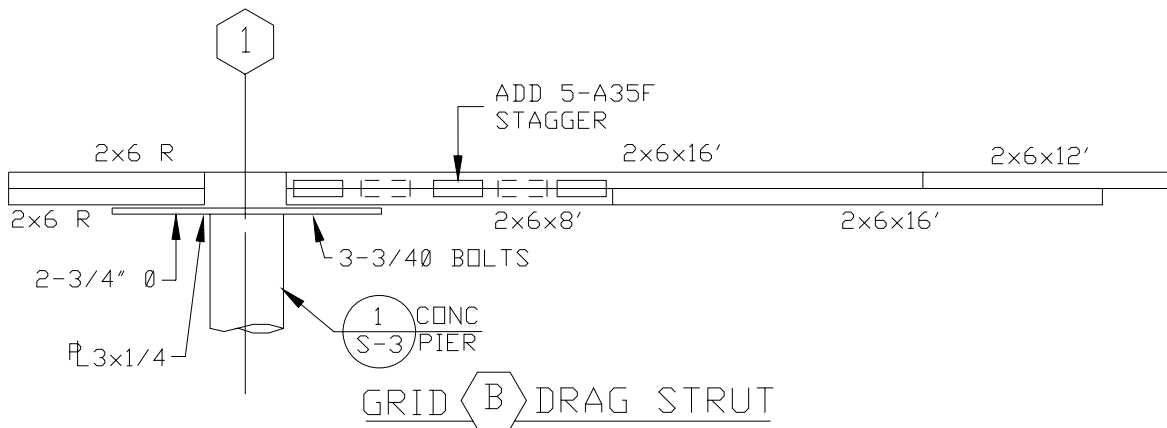
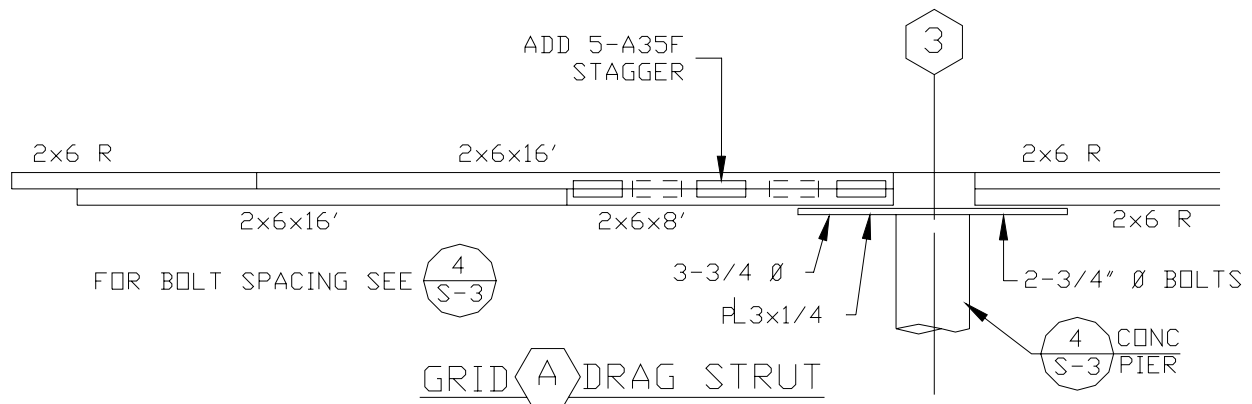

LEGEND

LENGTH FEET

MEMBER SIZE

R = REMAINING LENGTH

2-3/40 = NUMBER AND DIA. OF BOLTS THRU ϕ & 2-2x6

$\frac{6}{S-3}$ NORTH-SOUTH DRAG STRUT SPLICES
LOOKING EAST

